

VPX3U-RTX5000E-VO

NVIDIA Turing 11 TFLOPS, 384 Tensor Cores, 4 DP OUT

KEY FEATURES

- NVIDIA Quadro Turing TU104 GPU with 10.9 TFLOPS, 3072 CUDA Cores, 384 Tensor Cores, 48 RT Cores
- 16 GB GDDR6 256-bit memory with up to 448 GB/s
- Four DisplayPort outputs
- Module power: 50-150W

ADDITIONAL FEATURES

- Four DisplayPort 1.4 digital video outputs:
 - Support for High Dynamic Range (HDR) video
 - 4K at 120Hz or 8K at 60Hz with 10-bit color depth
 - HDMI and DVI options
- Turing GPGPU parallel processing:
 - 3072 CUDA® cores
 - CUDA Toolkit 10, CUDA Compute capability 7.5
 - OpenCL™ 1.2, DirectX® 12, OpenGL 4.6, OpenGL ES 3.2, Vulkan™ 1.0
- 384 Turing Cores for advanced AI inference processing
- 16 GB GDDR6 memory provides twice the bandwidth of the previous generation of GDDR5 memory
- HEVC (H.265) and AVC (H.264) Turing NVENC and NVDEC hardware acceleration with up to 8K encode resolution and B-frame support
- PCI Express x16
- Daisy Chain and NTB Options Available
- Windows and Linux drivers

SPECIFICATIONS

- High level of ruggedization:
 - Rugged Conduction cooled or Air cooled
 - Operating temperature: Conduction Cooled -40° to +85°C, Air cooled -40° to +71°C
 - Vibration (sine wave): 10G peak, 5 - 2000Hz
 - Shock: 30G peak for air-cooled, 40G peak for conduction-cooled
- Dimensions: 160mm x 100mm x 25.4mm
- Weight (approximately): 1564g for conduction cooled, 1414g for air cooled
- +12V or +5V Only Power Source Options
- ANSI/VITA 48, 65 (VPX-REDI, OpenVPX)
- SOSA Aligned options with depopulated P2 or support for the legacy payload slot profile

OVERVIEW

The VPX3U-RTX5000E-VO module includes an NVIDIA® Quadro® Turing™ RTX5000 embedded GPU in a rugged 3U VPX module. The RTX5000 includes CUDA cores for parallel processing, Tensor cores for dedicated AI inference and ray tracing cores for superior rendering speeds.

Getting data into and out of the module is an important consideration for this high-speed GPU. Support for GDDR6 memory provides twice the bandwidth of the previous generation's GDDR5 memory.

The Turing GPU with its Tensor cores provides this module with the underlying architecture required for an efficient AI inference engine. Intended to work in conjunction with TensorRT, CUDA and CuDNN, the Turing Tensor Core design adds INT8 and INT4 matrix operations, while continuing to support FP16 for higher precision workloads.

Unlocking the best performance requires the best cooling capability. WOLF's advanced cooling technology is designed to move heat using a low weight, high efficiency pipeline from the GPU die to the wedgelocks.

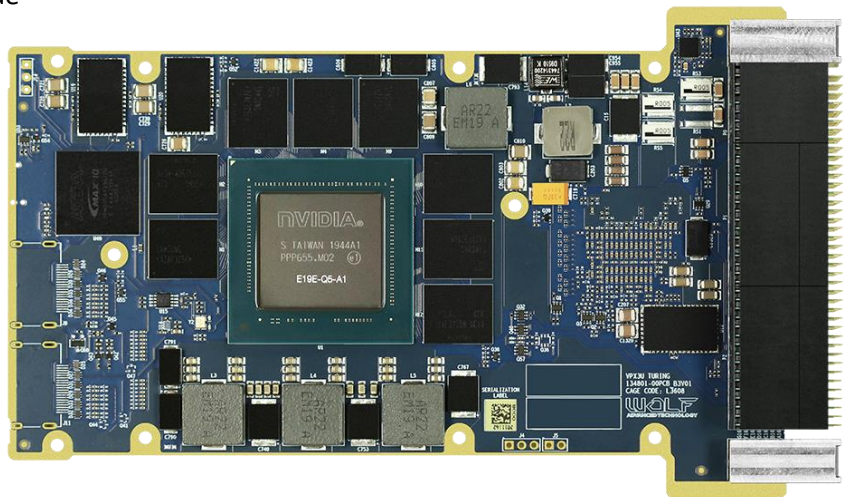

VPX3U-RTX5000E-VO

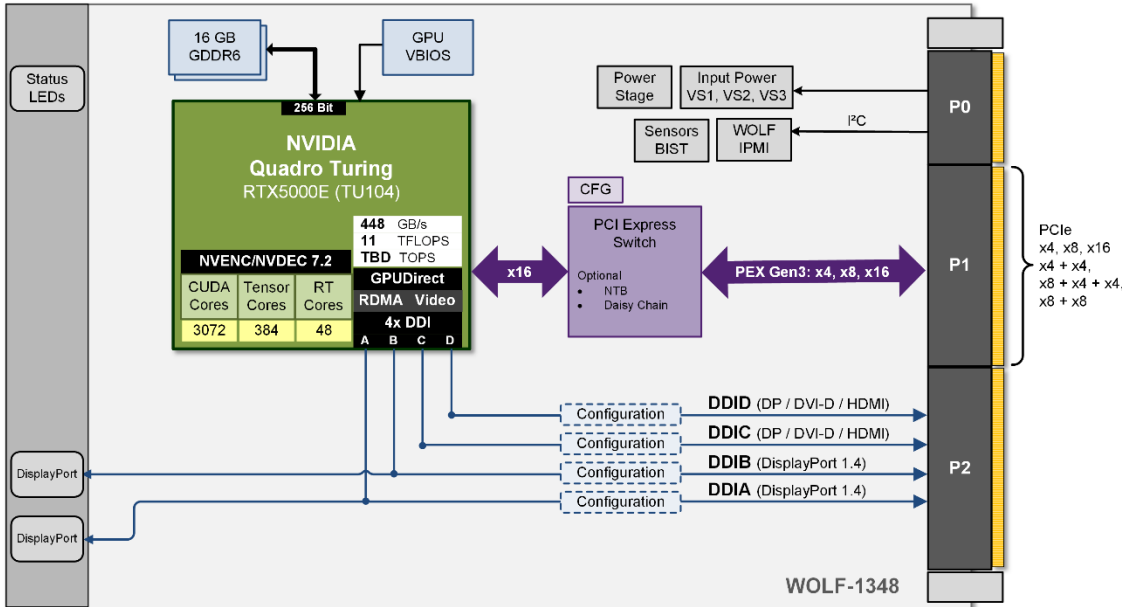

Standard model with video output over P2 or front panel connectors.

Support for several OpenVPX slot profiles with configurable PCIe.

*Front Panel Connectors on Air Cooled Versions Only

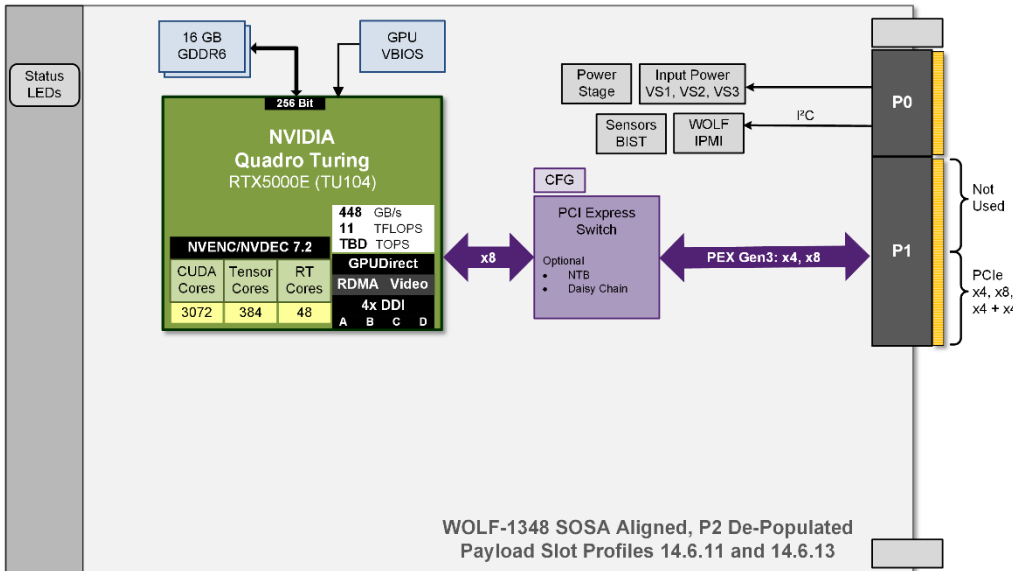

SOSA aligned model with support for Payload Slot Profiles 14.6.11 and 14.6.13.

The P2 connector is depopulated as per the SOSA requirements for these slot profiles and the model supports data processing. This model supports PCIe up to x8 over P1.

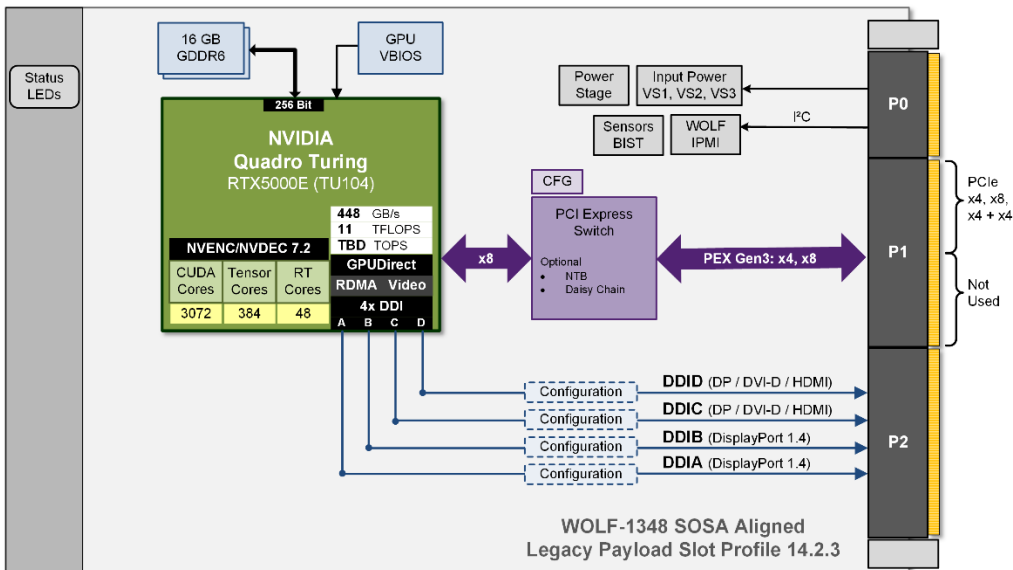

SOSA aligned model with support for Legacy Payload Slot Profile 14.2.3.

For this slot profile the P2 connector is populated and can be used for video output. This model supports PCIe up to x8 over P1.

NVIDIA TURING STREAMING MULTIPROCESSOR (SM)

The NVIDIA Turing architecture provides a 50% improvement in delivered performance per CUDA core compared to the Pascal generation. This is due to the new Turing Streaming Multiprocessor's independent integer datapath, allowing execution of concurrent integer and floating-point instructions, and the redesigned memory path which provides two times the bandwidth and more than two times the capacity for common workloads.

NVIDIA TENSOR CORES FOR ARTIFICIAL INTELLIGENCE AND HPC

Tensor Cores are designed to speed up the tensor / matrix computations used for deep learning neural network training and inferencing operations. Turing GPUs include a new version of the Tensor Core design that has been enhanced for inferencing. Turing Tensor Cores add new INT8 and INT4 precision modes for inferencing workloads that can tolerate quantization and don't require FP16 precision.

NVIDIA provides CUDA-X AI and CUDA-X HPC libraires which are specialized libraires built on top of CUDA. They have been designed to work with NVIDIA Tensor Core GPUs to provide the tools needed to accelerate development of applications for AI and HPC.

HARDWARE ACCELERATED VIDEO ENCODE / DECODE

The RTX5000E chip includes the latest generation video encode/decode hardware acceleration engine (version 7.2). This adds support for HEVC (H.265) 8K encoding at 30 fps and B-Frame support. It also provides up to 25% bitrate savings for HEVC and up to 15% bitrate savings for AVC (H.264). Using the Turing encoding engine for video encoding provides an efficient, high quality method to achieve real time 8K and 4K encoding without burdening the system CPU.

As with previous versions of the encoding engine, NVENC supports CBR and VBR rate control, programmable intra-refresh for error resiliency, and a motion estimation (ME) only mode. The NVIDIA Video Codec SDK provides a complete set of APIs, samples and documentation for hardware accelerated video encode and decode on Windows and Linux.

DESIGNED FOR SYSTEM INTEGRATION

The VPX architecture is diverse, spanning custom backplanes, an ambiguous system specification and differing input and output methodologies. That is why WOLF modules come with factory configuration options to solve virtually all system integration challenges.

The WOLF-1348 module has a configurable PCIe interface that supports several OpenVPX slot profiles. They can also be configured with pin mappings that are compatible with older generation WOLF-0197/1116 cards, which allows the WOLF-1348 to be a plug-in upgrade for those WOLF products.

The module can also be configured to be SOSA aligned for data processing only, with PCIe limited to x8 on VPX connector P1. With this configuration the following SOSA profiles can be supported:

- SLT3-PAY-1F1U1S1S1U1U2F1H-14.6.11-n Payload Slot Profile, P2 depopulated
- SLT3-PAY-1F1U1S1S1U1U4F1J-14.6.13-n Payload Slot Profile, P2 depopulated
- SLT3-PAY-2F2U-14.2.3 Legacy Payload Slot Profile

If a SOSA aligned module which includes video outputs is required then the WOLF-1349 is also recommended.

ORDERING CODES

The following table defines series of common order codes for the VPX3U-RTX5000E-VO module. The asterisks denote characters of the part number that are defined based on common configuration options. Some configuration options for this module include:

- Display Interfaces
- Conformal Coating Type
- COTS, MCOTS or Locked
- +12V / +5V Main Power
- Default Power Threshold
- P2 de-populated (SOSA Aligned)
- PCIe configuration

Ordering Number	Description
3U VPX Turing RTX5000 Single Slot Configurations	
134823-F001-000VPX3vA0	3U VPX, Air Cooled, 1", NVIDIA Turing RTX5000, Front IO: 2x DP++, Rear IO: 3x DP++
134833- F001-000VPX3vA0	3U VPX, Conduction Cooled, 1", NVIDIA RTX5000, Rear IO: 4x DP++
134823-F005-000VPX3vA0	3U VPX, Air Cooled, 1", NVIDIA Turing RTX5000, P2 depopulated
134833- F005-000VPX3vA0	3U VPX, Conduction Cooled, 1", NVIDIA RTX5000, P2 depopulated

Contact Sales for the latest Ordering Numbers and available options

MANUFACTURING AND QUALITY ASSURANCE

WOLF designs modules to pass the following environmental standards:

- MIL-STD-810 (United States Military Standard for Environmental Engineering Considerations and Laboratory Tests)
- MIL-HDBK-217 (Reliability Prediction of Electronic Equipment)
- RTCA DO-160 (Environmental Conditions and Test Procedures for Airborne Equipment) on request

WOLF complies with the following management systems:

- AS9100D: Quality Management System - Requirements for Aviation, Space and Defense Organizations (certified)
- ISO 9001:2015: Quality management systems (certified)
- AS5553: Counterfeit Electronic Parts; Avoidance, Detection, Mitigation, and Disposition (compliant)
- NIST SP 800-171: Protecting Controlled Unclassified Information in Nonfederal Systems (compliant)

Boards are manufactured to meet the following standards:

- IPC-A-610 CLASS 3 (Acceptability of Electronic Assemblies)
- IPC 6012 CLASS 3 (Qualification and Performance Specification for Rigid Printed Boards, Class 3 for High Reliability Electronic Products)
- IPC J-STD-001 (Requirements for Soldered Electrical and Electronic Assemblies)

