

VPX Carrier Cards

VPX4810 VPX Carrier Cards for XMC or PMC Modules

2
YEAR
WARRANTY

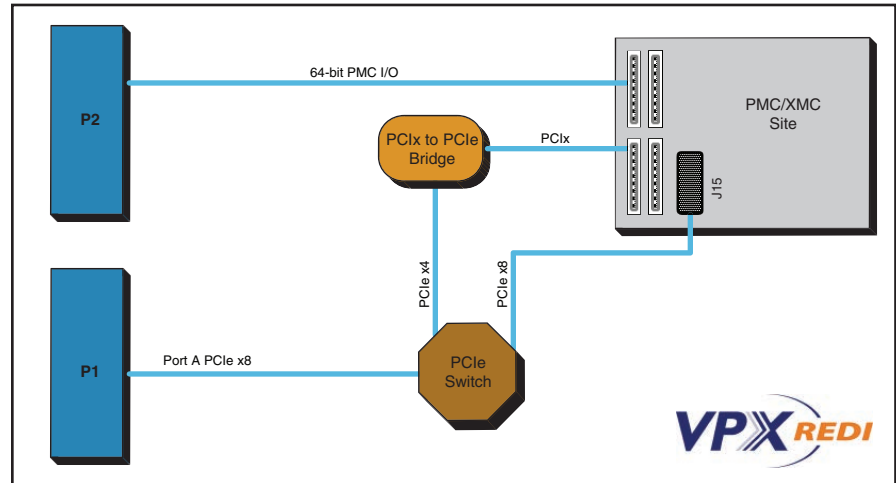
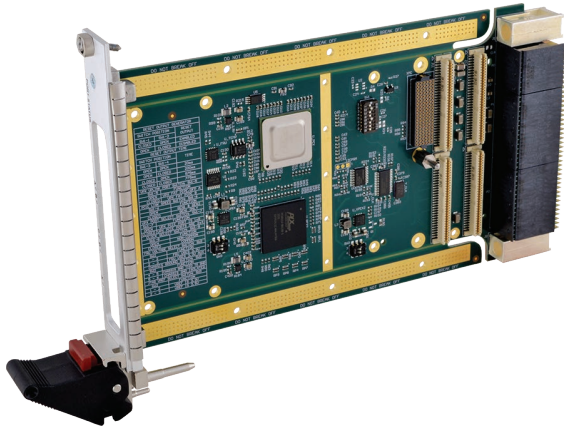

Air-cooled, conduction-cooled and REDI versions ◆ 3U ◆ One PMC/XMC slot ◆ PCIe x8 Gen 2 interface

Description

These 3U mezzanine carrier cards provide a simple and cost-effective solution for interfacing a PMC or XMC module to a VPX computer system. The carrier card routes power and bus signals to a plug-in mezzanine module through the VPX card slot connector. Industrial I/O and configurable FPGA modules from Acromag or other vendors are supported.

These carriers are ideal for high-performance industrial, defense, scientific research, and telephony systems requiring high-speed I/O expansion. The VPX4810-LF is available in three versions: air-cooled, conduction-cooled and a Ruggedized Enhanced Design Implementation (REDI VITA 48).

Key Features & Benefits

- PMC/XMC site uses 64-bit, 66/133MHz PLX technology with a PCIe to PCI-X bridge
- PCIe bus 8-lane Gen 1 or 2 interface
- Supports standard PMC/XMC modules (IEEE 1386.1)
- Conforms to VPX VITA 46.0, 46.4 and 46.9 specifications and VITA 48
- Supports front or rear panel PMC/XMC I/O
- Supports 64 I/O lines (P14, VITA 46.9) via the P2 VPX connector
- 3.3V PCI-X signaling PMC site
- +12V and -12V provided to PMC/XMC site
- Monitors FRU information and module temperature



Conduction-cooled version



VPX REDI VITA 48 version

Acromag  [®]
THE LEADER IN INDUSTRIAL I/O

Tel 248-295-0310 ■ Fax 248-624-9234 ■ solutions@acromag.com ■ www.acromag.com ■ 30765 Wixom Rd, Wixom, MI 48393 USA

VPX Carrier Cards

VPX4810 VPX Carrier Cards for XMC or PMC Modules

Performance Specifications

NOTE: Specifications for VPX4810 only.

■ General

Form Factor

3U VPX bus 6.299" (160mm) x 3.937" (100.0mm).

Pitch

VPX4810 (air-cooled): 1.0" pitch

VPX4810-CC (conduction-cooled): 0.85" pitch

VPX4810-REDI (conduction-cooled REDI): 1.00" pitch

Front Panel

The VPX4810-LF has a 1.0" VITA 48.1 front panel.

Contact the factory for IEEE 1101.10 1.0" and 0.8" options.

VPX Carrier Interface

Compatible VITA 65 module / slot profiles:

MOD3-PER-1F-16.3.2-2 / SLT3-PER-1F-14.3.2

MOD3-PAY-1D-16.2.6-1' / SLT3-PAY-1D-14.2.6

Note 1: Board is compatible with payload profiles but has no hosting capabilities.

FRU EEPROM with temperature monitor.

PMC/XMC Interface

One IEEE 1386.1 PMC/XMC module in single VPX slot.

PMC site is PCI 3.0 compliant, 32/64-bit, 33/66MHz.

PMC site is PCI-X 1.0b compliant, 64-bit, 66/100/133MHz.

XMC site is PCIe Gen. 2.0 and 8 lanes wide.

3.3V, 5V and $\pm 12V$ provided for PMC modules via the VPX backplane.

Front or rear panel I/O support for the PMC site with 64 I/O lines, or 32 differential pairs. Rear I/O is compliant to VITA 46.9 P2w1-P64s.

■ Power Requirements

Carrier-Only Power Requirements

+3.3V DC: 0.9A typical plus any additional power consumed by PMC/XMC.

+5V DC: 0.9A typical plus any additional power consumed by PMC and XMC (VPWR).

+12V DC and -12V DC provided to PMC and XMC site (aux only).

■ Environmental

Air-Cooled Operating Temperature

0 to 70°C (air flow requirement as measured to be greater than 200 LFM).

Conduction-Cooled Operating Temperature Range

-40 to 85°C (board must operate in a fully-installed conduction-cooled rack).

REDI (VITA 48) Operating Temperature Range

-40 to 85°C (board MUST operate in a fully-installed conduction-cooled, REDI supported rack).

Storage Temperature Range

-55 to 100°C.

Relative Humidity

5 to 95% non-condensing.

MTBF

2,652,569 hrs. at 25°C.

1,672,742 hrs. at 40°C.

Vibration

0.05g RMS (20 - 2000Hz) random, operating 6g RMS per Hz spectrum.

Shock

30g each axis, 11ms.

Ordering Information

Carrier Cards

[VPX4810-LF](#)

VPX carrier card, 3U, one PMC/XMC slot

[VPX4810-CC-LF](#)

Conduction-cooled version of VPX-4810

[VPX4810-REDI-LF](#)

Ruggedized enhanced design implementation (REDI VITA 48) version of VPX-4810-LF

Accessories

See www.acromag.com for more information.

Software Development Tools

See www.acromag.com for more information.

ISO9001
AS9100



Acromag 
THE LEADER IN INDUSTRIAL I/O

Tel 248-295-0310 ■ Fax 248-624-9234 ■ solutions@acromag.com ■ www.acromag.com ■ 30765 Wixom Rd, Wixom, MI 48393 USA