

Product Model: **MM122A Series**

Piezoelectric IEPE Accelerometer

Version: A Date: 17/3/2022

Sensor Feature:

Sturdy Construction

M5 or Integral Cable (Optional)

Shear design to reduce the influence of the environment on the signal

Uses: High Level mechanical shock and vibration measurement
Automotive crash testing

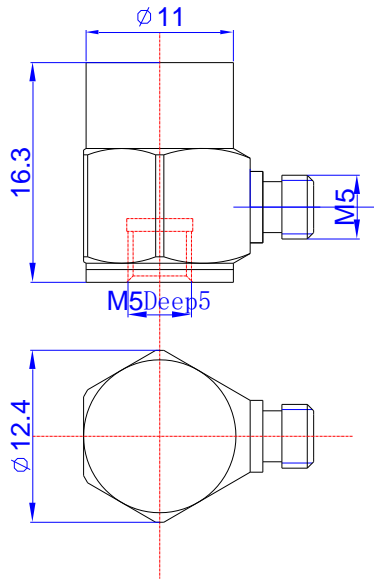

Model	MM122A-05
Sensitivity ($\pm 10\%$)	5 mV/g
Measurement Range	$\pm 1,000$ g
Resolution	5 mg rms
Frequency Range (± 1 dB)	1-10,000 Hz
Resonant Frequency	~ 40 kHz
Non-linearity	$\leq 1\%$
Temperature Range	-40 \sim +121 $^{\circ}\text{C}$
Transverse Sensitivity	$\leq 5\%$
Excitation Voltage	+18-+28 VDC
Excitation Current	2 - 10 mA
Output Impedance	$< 100 \Omega$
Output Bias Voltage	11 \pm 1.5 VDC
Sensing Element/Geometry	Ceramic/Shear
Size mm	As left figure
Weight	~ 12 g
Mounting	M5 (female)
Housing Material	Stainless Steel

Frequency Response

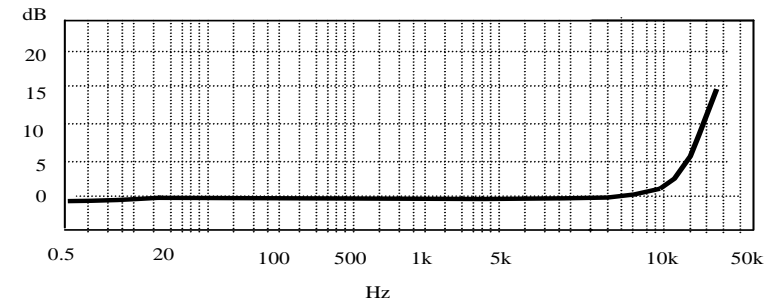

Temperature Response

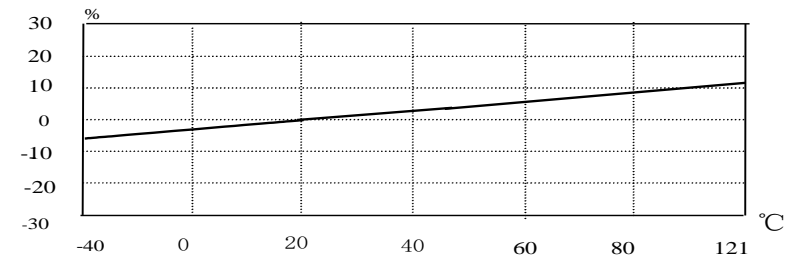

Metromatics

ABN: 47 007 346 287

Accessories

- 2 Metre Coaxial Shielded Cable 1ea
- Certificate of inspection 1ea + M5 Stud 1ea

25 Flinders Parade, North Lakes QLD 4509, AUSTRALIA
www.metromatics.com.au sales@metromatics.com.au
 Brisbane: +61 7 3868 4255 | Sydney: +61 2 9460 4355
 Melbourne: +61 3 9872 4592 | Adelaide: +61 8 8343 8516

Remark

Output Connector – M5 Side