

Product Model: **MM146A Series**

Tri-Axial Low Frequency Accelerometer

Version: A Date: 17/3/2022

Sensor Feature:

Shear design to reduce the influence of the environment on the signal

Using wide temperature coefficient ceramic material

Stable output in high and low temperatures

Case Isolation

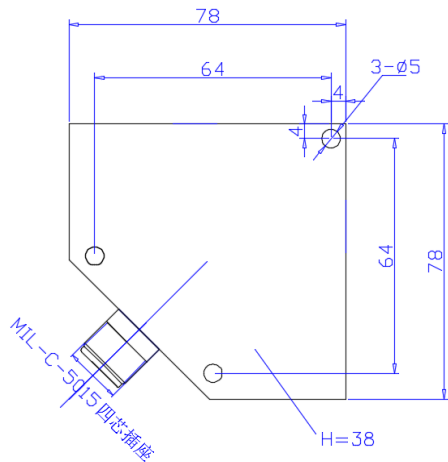

Model	MM146A-10G
Sensitivity ($\pm 10\%$)	10 Vg
Measurement Range	± 0.5 g
Resolution	0.01 mg rms
Frequency Range (± 1 dB)	0.3-300 Hz
Resonant Frequency	~ 8 kHz
Transverse Sensitivity	$\leq 5\%$
Temperature Range	-40 \sim +100 °C
Non-Linearity	$\leq 1\%$
Excitation Voltage	+18-+28 VDC
Excitation Current	2 - 10 mA
Output Impedance	$< 100 \Omega$
Output Bias Voltage	11 \pm 1.5 VDC
Sensing Element/Geometry	Ceramic/Shear
Size mm	As left figure
Weight	~ 1500 g (SS) ~ 550 g (Al)
Mounting	3- $\Phi 5$ (Thru-hole)
Housing Material	Stainless Steel or Aluminium

Frequency Response

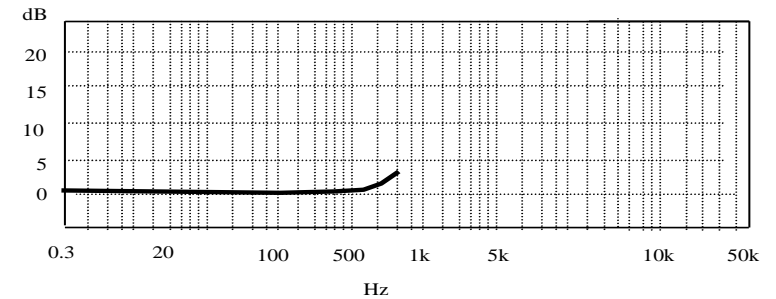

Temperature Response

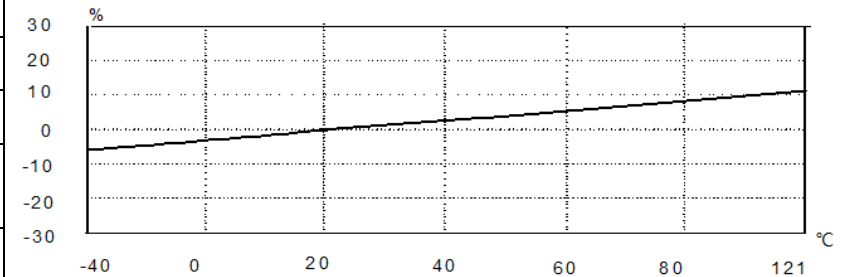

Metromatics

ABN: 47 007 346 287

Accessories

- 5 Metre 4 core Shielded cable x 1ea
- Certificate of inspection 1ea + M5 Blot 3ea

25 Flinders Parade, North Lakes QLD 4509, AUSTRALIA
www.metromatics.com.au sales@metromatics.com.au

Remark

Output Connector: 4-Pin MIL-C-5015 + Insulin Resistance: $\geq 10^8 \Omega$

Brisbane: +61 7 3868 4255 I Sydney: +61 2 9460 4355
 Melbourne: +61 3 9872 4592 I Adelaide: +61 8 8343 8516