

Product Model: **MM232A Series**

**High Sensitivity Accelerometer with Low Level Vibration**

Version: A Date: 17/3/2022

**Sensor Features:**

Stable output in high and low temperatures  
 Uses a wide temperature coefficient ceramic material  
 Shear Design to reduce the influence of the environment on the signal

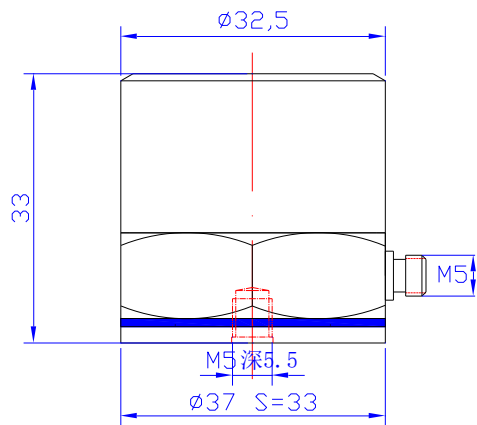

Model	MM232A-03
Sensitivity	3,000 pC/g
Measurement Range	$\pm 50$ g
Transverse Sensitivity	$\leq 5\%$
Frequency Range ( $\pm 1$ dB)	1,000 Hz
Resonant Frequency	$\sim 5$ kHz
Non-linearity	$\leq 1\%$
Temperature Range	-54 $\sim$ +150 $^{\circ}\text{C}$
Insulation Resistance	$\geq 10^9 \Omega$
Sensing Element/Geometry	Ceramic/Shear
Size mm	As left figure
Weight	$\sim 180$ g
Mounting	M5 (Female)
Output Connector	M5 Side
Housing Material	Stainless Steel
Sealing	Welded

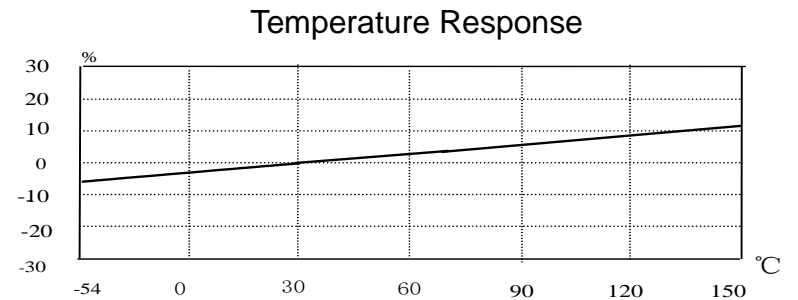
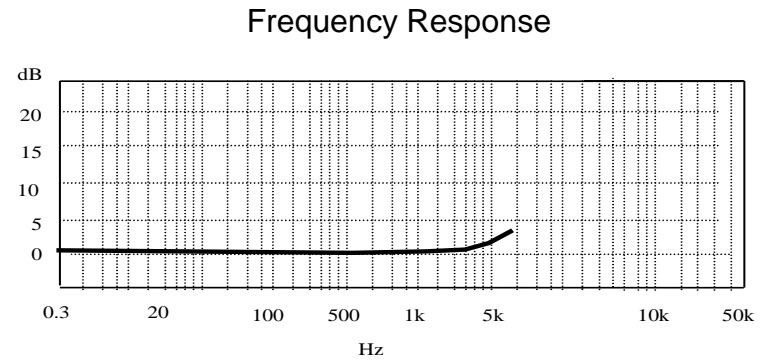

**Metromatics**

ABN: 47 007 346 287

**Accessories**

- 2M Low Noise High Temperature Cable 1 ea
- Certificate of inspection 1ea + M5 Stud 1ea

25 Flinders Parade, North Lakes QLD 4509, AUSTRALIA  
[www.metromatics.com.au](http://www.metromatics.com.au)      [sales@metromatics.com.au](mailto:sales@metromatics.com.au)  
 Brisbane: +61 7 3868 4255    |    Sydney: +61 2 9460 4355  
 Melbourne: +61 3 9872 4592    |    Adelaide: +61 8 8343 8516

**Remark**