

Product Model: **MM247A Series**

Piezoelectric PE Accelerometer

Version: A Date: 17/3/2022

Sensor Features:

Strong construction with Integral Cable
 Uses a wide temperature coefficient ceramic material

Uses:

High level mechanical shock and vibration measurement
 Automotive Crash Tests

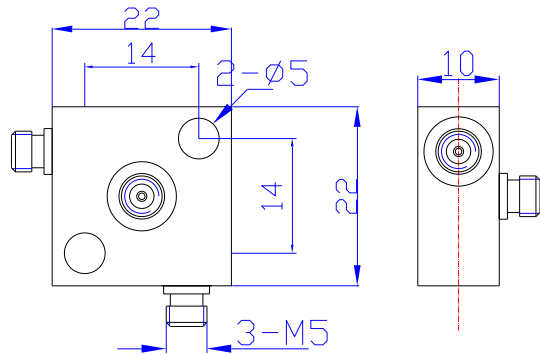

Model	MM247A-01
Sensitivity	1 pC/g
Measurement Range	±5,000 g
Transverse Sensitivity	-
Frequency Range (±1 dB)	8,000 Hz
Resonant Frequency	~30 kHz
Non-linearity	≤5%
Temperature Range	-40 ~ +65 °C
Insulation Resistance	≥10 ¹⁰ Ω
Sensing Element/Geometry	Ceramic/Shear
Size mm	As left figure
Weight	~40 g
Mounting	(2) Φ5 (Thru-Hole)
Output Connector	(3) M5
Housing Material	High Strength Stainless Steel
Sealing	Welded

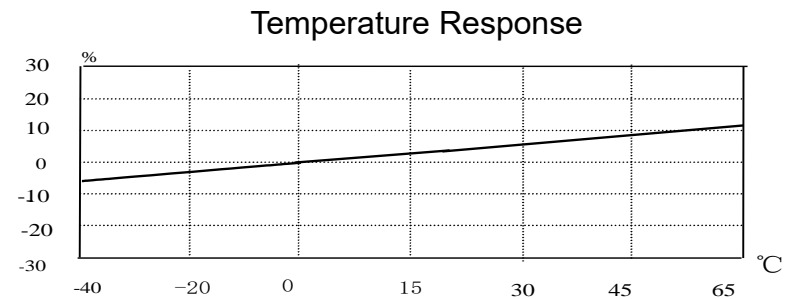
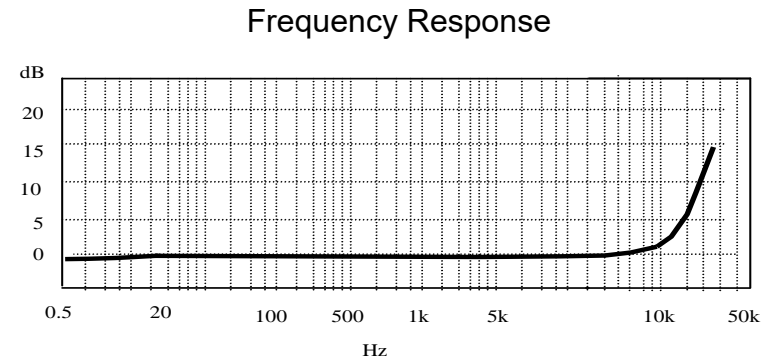

Metromatics

ABN: 47 007 346 287

Accessories

- 2M Integral Low Noise Cable 1 ea
- Certificate of inspection 1ea + M5 Screws 2ea

25 Flinders Parade, North Lakes QLD 4509, AUSTRALIA
www.metromatics.com.au sales@metromatics.com.au
 Brisbane: +61 7 3868 4255 | Sydney: +61 2 9460 4355
 Melbourne: +61 3 9872 4592 | Adelaide: +61 8 8343 8516

Remark