

VPX3U-AD2000E-VO

NVIDIA Ada, 3072 CUDA Cores, DP/HDMI/DVI Video

KEY FEATURES

- NVIDIA RTX™ 2000 (AD107) GPU with 3072 CUDA Cores, 96 Tensor Cores, 24 RT Cores
- 8 GB GDDR6 128-bit memory, up to 256 GB/s
- Up to 3 DisplayPort outputs, options for DVI/HDMI
- Module power: 45W to 100W, configurable

GPU FEATURES

- Ada GPGPU parallel processing:
 - CUDA Toolkit 12, CUDA Compute capability 8.9
 - CUDA-X AI and CUDA-X HPEC libraires
 - OpenCL™ 3.0, DirectX® 12 Ultimate, OpenGL 4.6, OpenGL ES 3.2, Vulkan™ 1.2
- 96 Tensor Cores (4th Gen)
- 24 Ray Tracing cores (3rd Gen)
- NVENC (8th Gen) and NVDEC (5th Gen) with up to 8K video encoding and hardware decoding support

CONNECTIVITY / SYSTEM MANAGEMENT

- IPMI system management
- NVIDIA GPUDirect RDMA support
- Configurable PCIe Gen4 switch
- Windows and Linux drivers
- Ada GPU support requires one of the following host CPUs: Intel H/HX/P/PX/S/U Class, AMD H/HS/U Class

MECHANICAL / OPEN SYSTEMS ARCHITECTURE

- High level of ruggedization:
 - Rugged conduction cooled (CC) or air cooled (AC)
 - Operating temperature: CC: -40° to +70°C standard, +85C config available; AC: -40° to +60°C standard, +71C config available
 - Vibration (sine wave): 10G peak, 5 - 2000Hz
 - Shock: CC: 40G peak; AC: 30G peak
- Dimensions: 160mm x 100mm x 25.4mm
- Weight (approximately): CC: 1.4kg
- ANSI/VITA 48, 65 (VPX-REDI, OpenVPX)
- SOSA™ Aligned profile support 14.6.11 (with P2 depopulated) or the SOSA Legacy payload slot profile 14.2.3

OVERVIEW

The VPX3U-AD2000E-VO module includes an NVIDIA RTX™ 2000 Ada embedded GPU and a PCIe Gen4 switch in a rugged 3U VPX module. The NVIDIA RTX 2000 embedded GPU provides the advanced processing capabilities for high performance embedded computing (HPEC) and artificial intelligence (AI) processing.

The NVIDIA Ada architecture includes CUDA cores for HPEC, 4th generation Tensor cores for AI and data science computations, and 3rd generation Ray Tracing (RT) cores for visually accurate rendering. The Ada GPU uses a new TSMC 4N NVIDIA Custom Manufacturing Process which to increased efficiency. The denser Ada GPUs have more CUDA and Tensor cores operating at higher clock frequencies at the same power, delivering significantly more performance per watt compared to WOLF's previous generation product. For example, comparing the 1478 to the 1578, the 1578 can achieve up to two times the GFLOPS/W (depending on power and GPU temperature).

Unlocking the best performance requires the best cooling capability. WOLF's advanced cooling technology is designed to move heat using a low weight, high efficiency path from the GPU die to the wedgelocks.



This information is subject to change

The VPX3U-AD2000E-VO module uses a WOLF chip-down design to provide NVIDIA's advanced Ada architecture GPU technology on an extremely rugged board, making it an excellent choice for aerospace and defense applications. WOLF designs and manufactures these modules in North America with full component traceability.

The OpenVPX model supports DisplayPort/HDMI/DVI output, with PCIe over P1.

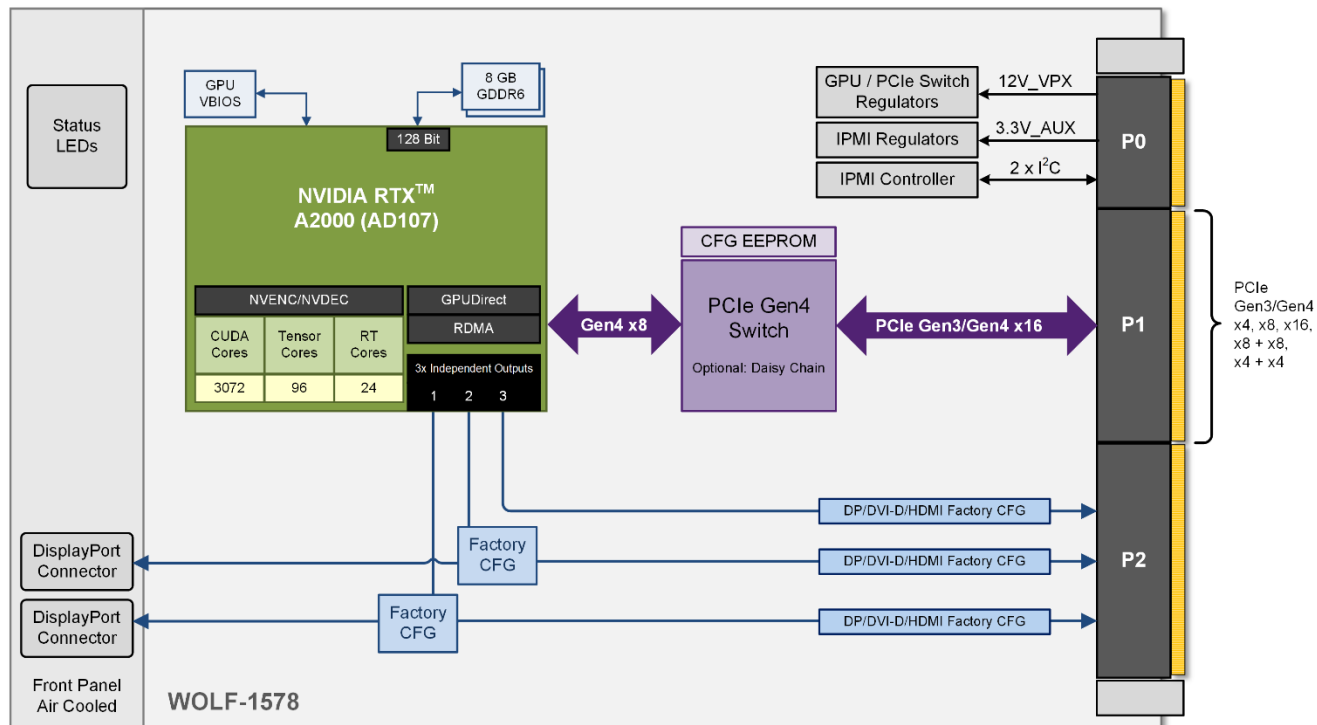

The SOSA Aligned HPC model supports slot profile 14.6.11 with PCIe supported on P1B.

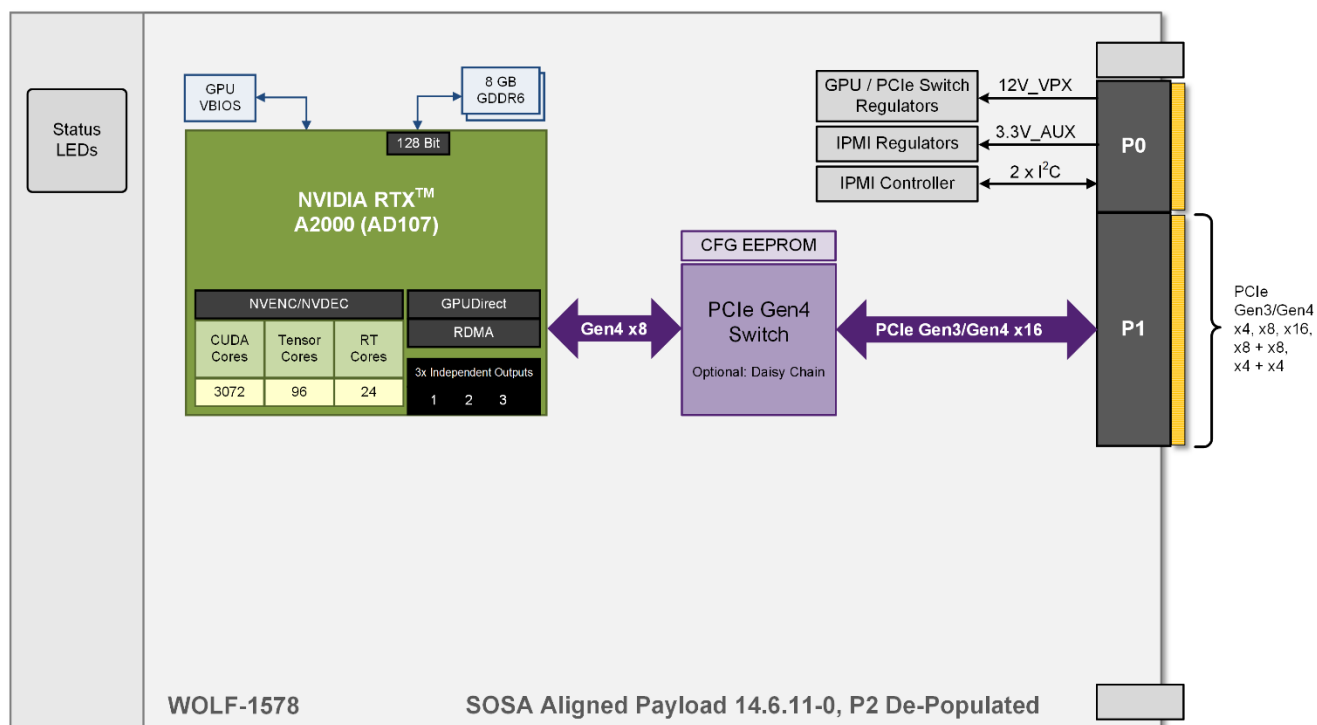

This information is subject to change

POWER AND PERFORMANCE

An NVIDIA GPU will operate at the GPU clock speed available at the set TGP (total GPU subsystem power). The highest clock speeds are available at the highest TGP power allowed by the GPU. When the TGP setting is decreased the clock speed will also decrease resulting in a decrease in processing speed. The GPU base clock speed will also decrease if the GPU temperature exceeds 89°C to protect the GPU from heat damage. If the GPU temperature is below 87°C the GPU can operate at full boost clock speeds when higher processing is required.

The Ada AD107 GPU typically operates at TGP power levels from 35W to 115W. At 100W the base clock of 2160 MHz provides 13.3 TFLOPS FP32 performance while the boost clock of 2355 MHz provides 14.5 TFLOPS. At 35W the base clock of 930 MHz provides 5.7 TFLOPS while the boost clock of 1445 MHz provides 8.9 TFLOPS.

NVIDIA ADA GPU

NVIDIA Ada GPUs are manufactured using a new TSMC 4N NVIDIA Custom Manufacturing Process, an enhanced version of the N5 (5nm) node process. This allows a higher transistor density and lower voltage requirements, which provides increased efficiency. As a result, Ada GPUs have many more CUDA cores at the same die size as the previous generation, and higher clock speeds at the same power level, which leads to greatly increased processing/watt compared to the previous generation. The new Ada architecture also provides a big increase in the GPU's memory cache size, providing a boost to memory subsystem handling at the same bandwidth. With the increased performance and memory handling abilities, and improved next gen Tensor cores and RT Cores, the Ada GPUs are able provide significant performance increases compared to the previous generation.

TENSOR CORES FOR ARTIFICIAL INTELLIGENCE AND HPEC

Tensor Cores are designed to speed up the tensor / matrix computations used for deep learning neural network training and inferencing operations. NVIDIA Ada architecture GPUs include the fourth-generation Tensor Core design which supports many data types for improved performance, efficiency, and programming flexibility, including a sparsity feature, a Tensor Float 32 (TF32) precision mode, and a new FP8 precision mode.

NVIDIA provides CUDA-X AI and CUDA-X HPEC libraires which have been designed to work with NVIDIA Tensor Core GPUs to provide the tools needed to accelerate development of applications for AI and HPEC.

HARDWARE ACCELERATED VIDEO ENCODE / DECODE

The Ada GPU includes the NVENC video encode and NVENC decode hardware acceleration engine. Using the GPU for video encoding provides an efficient, high quality method to achieve real time 8K and 4K encoding without burdening the system CPU. The Ada encoding engine includes support for several popular codecs and is the first GPU to include AV1 hardware encoding and decoding support. The NVIDIA Video Codec SDK provides a complete set of APIs, samples and documentation for hardware accelerated video encode and decode.

SOSA SLOT PROFILE SUPPORT

This module's configurable switch provides support for SOSA aligned slot profiles. The module can be configured with pin mappings that are compatible with older generation WOLF-1378 and WOLF-1478 modules, which allows the WOLF-1578 to be a plug-in upgrade for previous WOLF products.

The following SOSA aligned profiles are supported:

- 14.6.11-0 Payload Slot Profile, P2 depopulated
- 14.2.3 Legacy Payload Slot Profile

This information is subject to change

ORDERING CODES

The following table defines series of common order codes for the VPX3U-AD2000E-VO module. The asterisks denote characters of the part number that are defined based on common configuration options. Some configuration options for this module include:

- Display Interfaces
- Conformal Coatings
- Variant Locked
- Default Power Threshold
- PCIe Configuration Options
- SOSA or OpenVPX profiles

Ordering Number	Description
3U VPX Ada AD2000 Single Slot Configurations	
157833-F***-***VPX3vA0	3U VPX, Conduction Cooled, 1", OpenVPX, NVIDIA Ada RTX 20000, 8GB GDDR6, PCIe up to Gen4, Rear: 3x DP/HDMI/DVI out
157823-F***-***VPX3vA0	3U VPX, Air Cooled, 1", OpenVPX, NVIDIA Ada RTX 20000, 8GB GDDR6, PCIe up to Gen4, Rear: 1x DP/HDMI/DVI out, Front: 2x DP/HDMI/DVI
157833-F***-***VPX3vA0	3U VPX, Conduction Cooled, 1", SOSA 14.6.11 with P2 depopulated, NVIDIA Ada RTX 20000, 8GB GDDR6, PCIe up to Gen4, no video output

* Contact Sales for the latest Ordering Numbers and available options.

MANUFACTURING AND QUALITY ASSURANCE

WOLF designs modules to pass the following environmental standards:

- MIL-STD-810 (United States Military Standard for Environmental Engineering Considerations and Laboratory Tests)
- MIL-HDBK-217 (Reliability Prediction of Electronic Equipment)
- RTCA DO-160 (Environmental Conditions and Test Procedures for Airborne Equipment) on request

WOLF complies with the following management systems:

- AS9100D: Quality Management System - Requirements for Aviation, Space and Defense Organizations (certified)
- ISO 9001:2015: Quality management systems (certified)
- AS5553: Counterfeit Electronic Parts; Avoidance, Detection, Mitigation, and Disposition (compliant)
- NIST SP 800-171: Protecting Controlled Unclassified Information in Nonfederal Systems (compliant)

Boards are manufactured to meet the following standards:

- IPC-A-610 CLASS 3 (Acceptability of Electronic Assemblies)
- IPC 6012 CLASS 3 (Qualification and Performance Specification for Rigid Printed Boards, Class 3 for High Reliability Electronic Products)
- IPC J-STD-001 (Requirements for Soldered Electrical and Electronic Assemblies)

