

Product Model: **MM261A Series**

## Miniature Single Axis PE Accelerometer

Version: A Date: 17/3/2022

**Sensor Features:**

- Ceramic material with wide temperature coefficient
- Stable output in high and low temperatures
- Shear design to reduce the influence of the environment on the signal

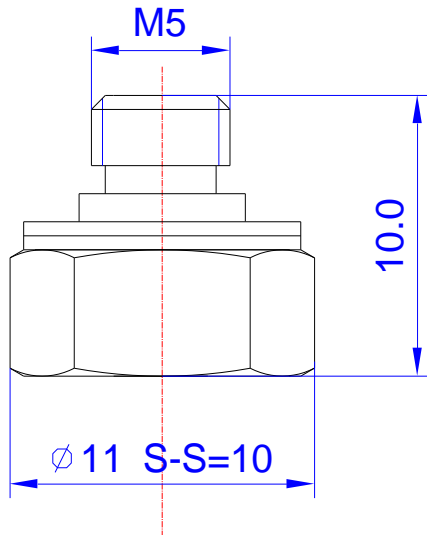

Model	MM261A-05
Sensitivity ( $\pm 10\%$ )	3 pC/g
Measurement Range	$\pm 2,000$ g
Frequency Range ( $\pm 1$ dB)	10,000 Hz
Transverse Sensitivity	$\leq 5\%$
Resonant Frequency	$\sim 45$ kHz
Non Linearity	$\leq 1\%$
Temperature Range	-54 $\sim$ +150 °C
Insulation Resistance	$\geq 10^{10}\Omega$
Housing Material	Stainless Steel
Sensing Element	Ceramic/Shear
Size mm	As left figure
Weight	$\sim 3.2$ g
Mounting	Adhesive
Output Connector	M5 Top

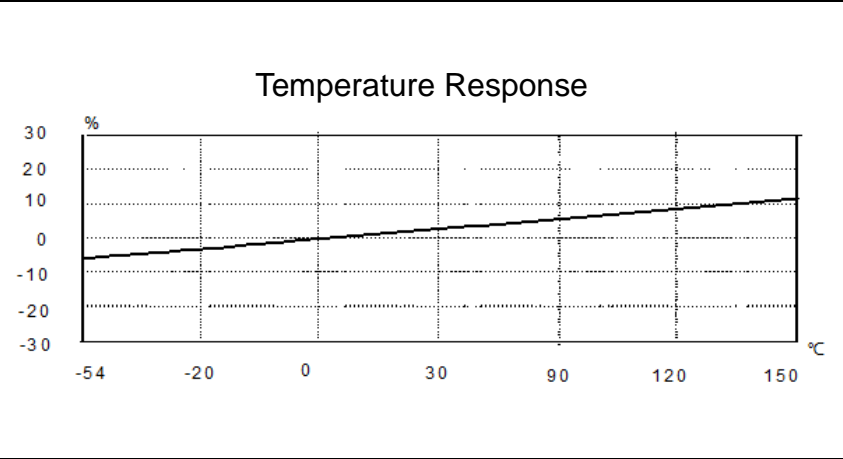
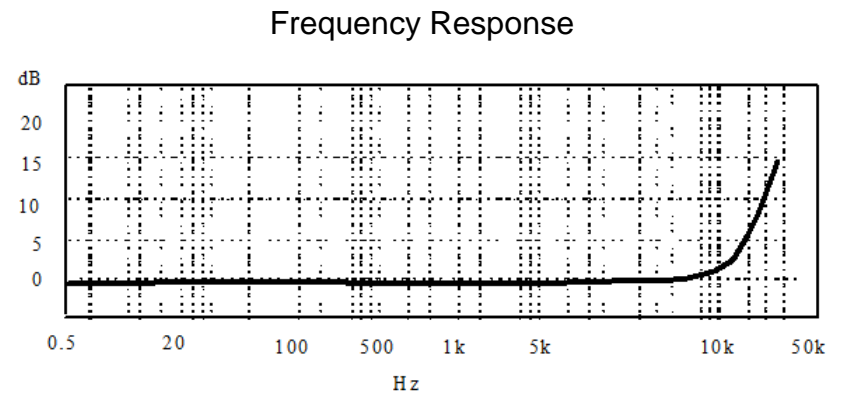

**Metromatics**

ABN: 47 007 346 287

Accessories	• Certificate of inspection 1ea + 2M Low Noise cable 1ea
-------------	--

Remark	
--------	--

25 Flinders Parade, North Lakes QLD 4509, AUSTRALIA  
[www.metromatics.com.au](http://www.metromatics.com.au)      [sales@metromatics.com.au](mailto:sales@metromatics.com.au)  
 Brisbane: +61 7 3868 4255    |    Sydney: +61 2 9460 4355  
 Melbourne: +61 3 9872 4592    |    Adelaide: +61 8 8343 8516