

Product Model: **MM263A Series**

Miniature Single Axis PE Accelerometer

Version: A Date: 17/3/2022

Sensor Features:

- Ceramic material with wide temperature coefficient
- Stable output in high and low temperatures
- Shear design to reduce the influence of the environment on the signal

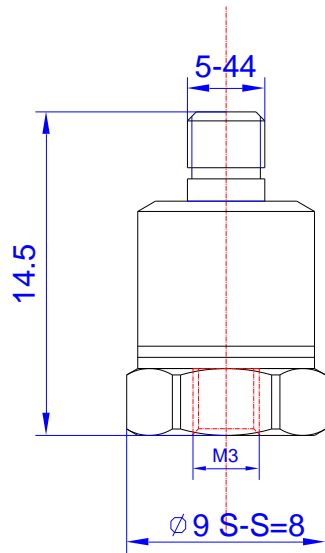

Model	MM263A-03
Sensitivity ($\pm 10\%$)	3.5 pC/g
Measurement Range	$\pm 3,000$ g
Frequency Range (± 1 dB)	12,000 Hz
Transverse Sensitivity	$\leq 5\%$
Resonant Frequency	~ 45 kHz
Non Linearity	$\leq 1\%$
Temperature Range	-54 \sim +150 °C
Insulation Resistance	$\geq 10^{10}\Omega$
Housing Material	Stainless Steel
Sensing Element	Ceramic/Shear
Size mm	As left figure
Weight	~ 5 g
Mounting	M3 (Female) or Adhesive
Output Connector	M5 or M-44 Side

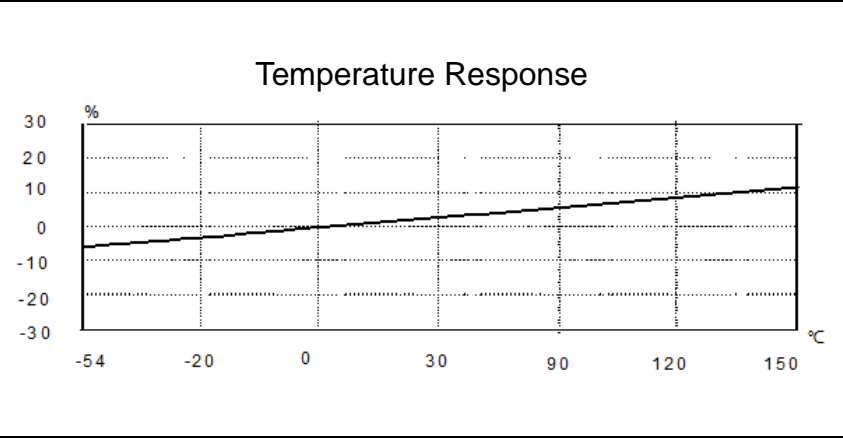
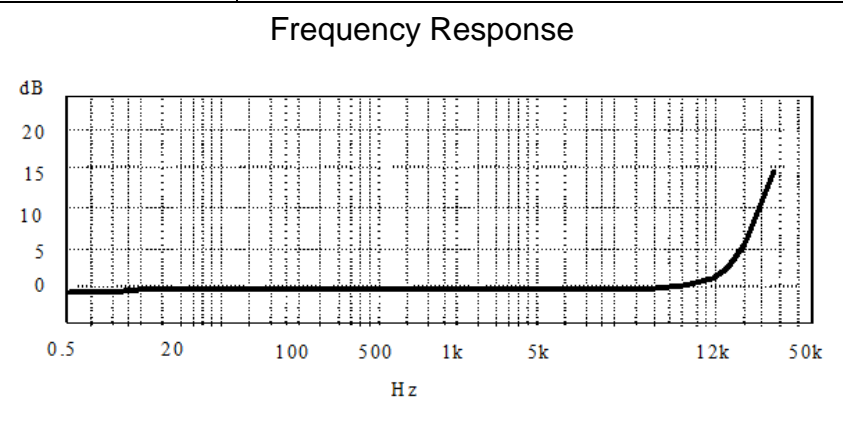

Metromatics

ABN: 47 007 346 287

Accessories

- Certificate of inspection 1ea + 2M Low Noise cable 1ea + M3/M5 Stud 1ea M3 (Female) Mounting Type

Remark

25 Flinders Parade, North Lakes QLD 4509, AUSTRALIA
www.metromatics.com.au sales@metromatics.com.au
 Brisbane: +61 7 3868 4255 I Sydney: +61 2 9460 4355
 Melbourne: +61 3 9872 4592 I Adelaide: +61 8 8343 8516