

VN-210-A TACTICAL GNSS/INS

Sensor Datasheet (Hardware v3.0)

HIGHLIGHTS

0.05°-0.1°

Dynamic Heading
Accuracy

< 1°/hr

Gyro In-Run Bias
Stability

Multi-band GNSS

Integrated L1/L2/E1/E5b
GNSS Receiver

MIL-STD VN-210

MIL-STD-810; MIL-STD-461G;
DO-160G; IP 68

0.015°

Dynamic Pitch/Roll
Accuracy (INS)

External GNSS

Support for external RTK/PPK
& SAASM/M-Code GPS

RTK/PPK Capable

External RTCM 3 Inputs;
Exportable RINEX

Low SWaP

56 x 56 x 31 mm;
155 grams; < 2.7 W

Product Overview

The VN-210-A is a tactical-grade, high performance GNSS-Aided Inertial Navigation System (GNSS/INS) that combines 3-axis gyros, accelerometers and magnetometers, a Multi-band L1/L2/E1/E5b GNSS receiver, and advanced Kalman filtering algorithms to provide optimal estimates of position, velocity, and attitude. The VN-210-A utilizes VectorNav's proprietary onboard Extended Kalman Filter (EKF) to optimally combine high bandwidth inertial sensor measurements with high-accuracy, low bandwidth GNSS measurements to provide high-accuracy, low latency position, velocity, and attitude measurements.

Calibration and Testing

Each individual VN-210-A Rugged sensor undergoes a robust calibration and acceptance testing process at VectorNav's AS9100 certified manufacturing facility. Performance specifications are based on comprehensive field testing and results from real-world applications and are regularly tested to ensure continued conformance to such specifications.

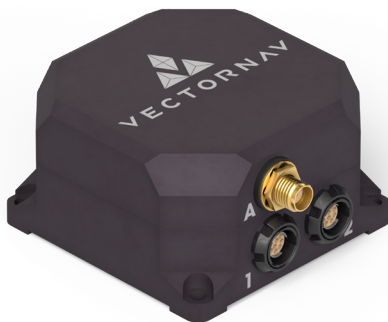

VN-210-A

Features

Industry-Leading INS

The VN-210-A features VectorNav's proprietary Extended Kalman Filter INS algorithm, which is proven to excel under the most challenging dynamic conditions.

True Inertial Navigation System

No mounting orientation restrictions or configuration modes; Automatic filter initialization and dynamic alignment.

Ease of Availability

ITAR-free and Made in the USA; short lead times.

Robust Positioning

With support for RTK, PPK & SAASM/M-Code GPS, the VN-210-A can be configured to meet the positioning requirements of a wide variety of

Software Compatibility

The VN-210-A shares a common communication protocol with the entire VectorNav product line.

User Configurable Messages

ASCII and VectorNav Binary messages.

Sensor Summary

- ▶ Hard/Soft Iron Compensation (Real-time and Manual 2D & 3D)
- ▶ Individually calibrated for bias, scale factor, misalignment, and temperature over full operating range (-40°C to +85 °C)
- ▶ RTK Capable: Support for External RTCM 3 Inputs
- ▶ Raw GNSS Data: Exportable RINEX Data for PPK; Raw Pseudorange, Doppler and Carrier Phase outputs
- ▶ Support for external RTK GNSS receivers & SAASM/M-Code GPS receivers
- ▶ Coning and sculling integrals (ΔV 's, $\Delta \theta$'s)
- ▶ Data output format: ASCII (VectorNav), NMEA-0183, Binary (VectorNav), ARINC 4291

CONTENTS

1 INS PERFORMANCE	3	4.1 Size	9
2 IMU SPECIFICATIONS	4	4.2 Environmental	10
2.1 Accelerometer	4	5 ELECTRICAL	11
2.2 Gyroscope	5	5.1 Power	12
2.3 Magnetometer	6	5.2 General Purpose I/O	13
3 GNSS RECEIVER	7	5.3 Communication	15
3.1 Receiver Specifications	7	6 PRODUCT HANDLING AND INSTALLATION	17
3.2 Supported Frequencies	7	6.1 Alignment and Fastening	17
3.3 Antenna Requirements	7	6.2 Magnetic and Vibration Considerations . .	17
3.4 RTK/PPK	8	6.3 Maintenance	17
4 MECHANICAL	9	6.4 Cabling	17

VectorNav Support

Whether you are looking for details on the VN-210 or assistance with your application, a wealth of information is available to assist you in product design and development. Check out the *Inertial Systems Primer* on our website, and be sure to register for access to a wide range of resources:

PRODUCT SPECIFICATIONS

- User Manual
- Interface Control Document
- Datasheet
- Quick Start Guide

TECHNICAL NOTES

- Time Synchronization
- Hard & Soft Iron Calibration
- External GNSS Aiding
- Firmware Update

APPLICATION NOTES

- Gimbal Stabilization & Pointing
- Satellite Communications
- Lidar Mapping
- Aerial Photogrammetry

All VectorNav products are backed by our customer-focused, robust and responsive support ecosystem. Our team is committed to supporting you through your entire product life-cycle, from concept design to in-field support. Please feel free to contact us by phone or email, our global team of engineers and representatives is ready to work with you through every challenge you know of, and every challenge you don't.

+1.512.772.3615

support@vectornav.com

1 INS PERFORMANCE

Attitude

SPECIFICATION	MIN	TYP	MAX	UNITS	NOTES
Range (Heading/Yaw, Roll)	-180		180	deg	
Range (Pitch)	-90		90	deg	
Output Rate		400		Hz	User configurable.
Heading (Magnetic)		2		deg	RMS[1]
Heading (INS)		0.05-0.1		deg	1 σ [2]
Pitch/Roll (Static)		0.05		deg	RMS
Pitch/Roll (INS)		0.015		deg	1 σ [2]
Heading Mounting Misalignment			0.05	deg	1 σ [3]
Pitch/Roll Mounting Misalignment			0.05	deg	1 σ [3]
Angular Resolution		0.001		deg	
Heave Accuracy		5 or 5%		cm	
Delayed Heave Accuracy		2 or 2%		cm	

[1] With proper magnetic declination, suitable magnetic environment and valid hard/soft iron calibration.

[2] With sufficient motion for dynamic alignment.

[3] Constant on a per part basis. Can be calibrated out during system integration using boresighting or other alignment processes.

TABLE 1

Position/Velocity

SPECIFICATION	MIN	TYP	MAX	UNITS	NOTES
Output Rate		400		Hz	User configurable.
Horizontal Position Accuracy		1		m	RMS[1]
Vertical Position Accuracy		1.5		m	RMS[1]
RTK Position Accuracy		1 + 1 ppm		cm	CEP
Free Inertial Position Drift		0.5		cm/s ²	[2]
Velocity Accuracy		0.02		m/s	RMS

[1] Dependent on SBAS, clear view of GNSS satellites, good multipath environment, compatible GNSS antenna, and measurement duration period.

[2] Typical rate of growth in error of position estimates after loss of GNSS signal, provided INS full alignment prior to loss.

TABLE 2

2 IMU SPECIFICATIONS

2.1 Accelerometer

Accelerometer

SPECIFICATION	MIN	TYP ±15	MAX	UNITS	NOTES
Range				g	
In-Run Bias Stability			10	μg	
Noise Density			0.04	mg/√Hz	
Sample Rate		800		Hz	
Bandwidth		200		Hz	
Cross-Axis Sensitivity			0.05	deg	
Resolution		0.1		mg	

TABLE 3

Allan Deviation

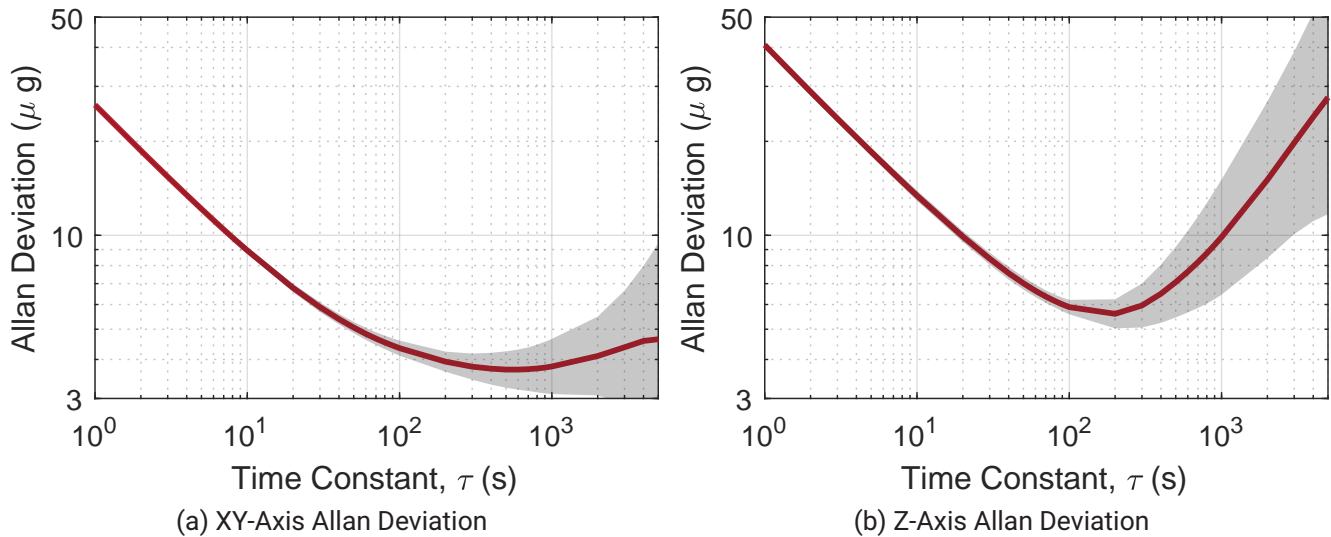

FIGURE 1

2.2 Gyroscope

Gyroscope

SPECIFICATION	MIN	TYP	MAX	UNITS	NOTES
Range		±490		°/s	[1]
In-Run Bias Stability		0.6	1	°/hr	
Noise Density		5		°/hr/√Hz	
Sample Rate		800		Hz	
Bandwidth		210		Hz	
Cross-Axis Sensitivity			0.05	deg	
Resolution		20		°/hr	

[1] Contact VectorNav for Extended Range Gyro option up to 2000 °/s.

TABLE 4

Allan Deviation

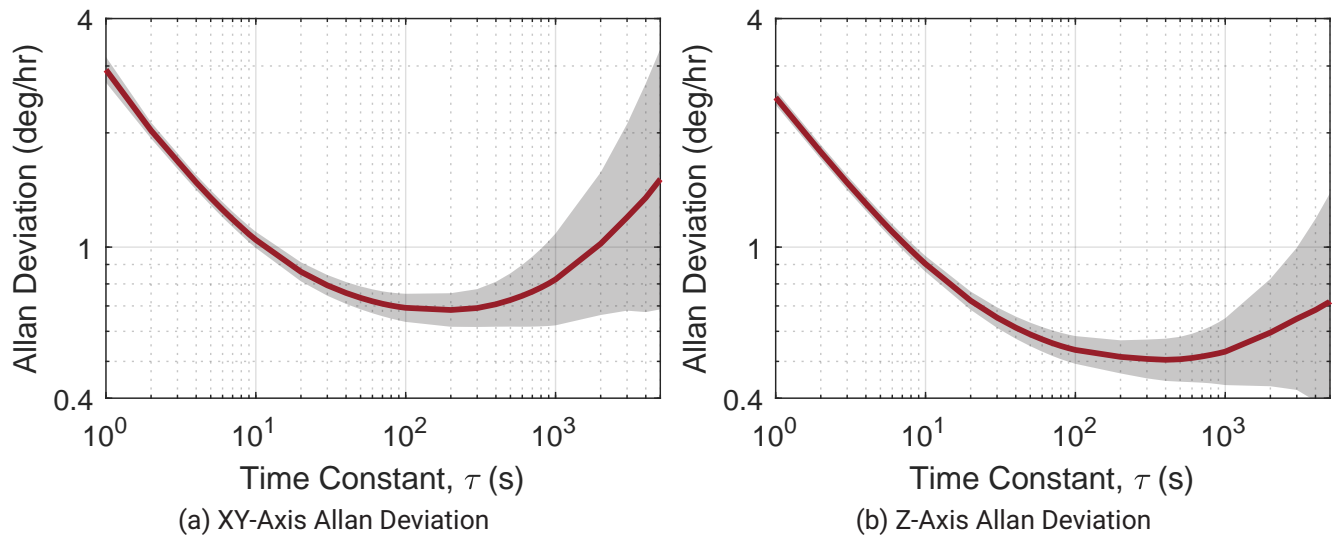

FIGURE 2

2.3 Magnetometer

Magnetometer

SPECIFICATION	MIN	TYP	MAX	UNITS	NOTES
Range		±2.5		G	
Noise Density		140		μG/√Hz	
Sample Rate		250		Hz	
Cross-Axis Sensitivity			0.05	deg	
Resolution		1.5		mG	

TABLE 5

3 GNSS RECEIVER

3.1 Receiver Specifications

GNSS Receiver Specifications

SPECIFICATION	MIN	TYP	MAX	UNITS	NOTES
Solution Update Rate		5		Hz	
Time-to-First-Fix					
Cold Start		29		s	
Hot Start		1		s	
Sensitivity					
Tracking		-167		dBm	
Reacquisition		-160		dBm	
Cold Start		-148		dBm	
Max RF Power			10	dBm	[1]
Altitude Limit			50000	m	
Velocity Limit			500	m/s	

[1] Measured at the GNSS connector.

TABLE 6

3.2 Supported Frequencies

- GPS - L1C/A, L2C
- Galileo - E1-B/C, E5b
- GLONASS - L10F, L20F
- BeiDou - B1I, B2I
- QZSS - L1C/A & L2C
- SBAS - L1C/A

3.3 Antenna Requirements

GNSS Antenna Electrical Requirements

SPECIFICATION	MIN	TYP	MAX	UNITS	NOTES
Input Voltage		5		V	
Current Draw			100	mA	Per antenna
Short-Circuit Current Limit Response Time		5		μs	
Gain	20		50	dB	
Noise			4	dB	

TABLE 7

3.4 RTK/PPK

The VN-210-A is able to accept RTCMv3 (Radio Technical Commission for Maritime Services) messages for RTK (Real-Time Kinematic) correction data on either UART-1 or UART-2. There are no requirements from the user to configure any settings prior to sending RTCM messages to the sensor. The sensor will automatically detect the RTCM messages and apply the corrections. It is recommended that the real-time link be capable of transferring correction data at an update rate of at least 1 Hz with minimal latency. It is also important that the communication baud rate be configured correctly.

The VN-210-A is able to output raw carrier phase data including pseudorange and Doppler data. In order to produce RINEX (Receiver Independent Exchange Format) data for PPK (Post-Processed Kinematic) corrections the user will have to configure the VN-210-A to output Raw GNSS data from Binary Group 4 GNSS1 Outputs, this logged data can then be converted to the RINEX data format using VectorNav's Control Center. Control Center is freely available from VectorNav's website: www.vectornav.com. Note that this data is available at 5 Hz.

Recommended Antennas

MANUFACTURER	MODEL	TYPE	NOTES
Tallysman	TW7882	Patch	General Purpose
Tallysman	TW8889	Patch	Smaller form factor
Tallysman	HC882	Helical	
ANTCOM	42GNSSA-XX-X	Patch	
ANTCOM	3GNSSA-XX-X	Patch	

TABLE 8

4 MECHANICAL

4.1 Size

Dimensions

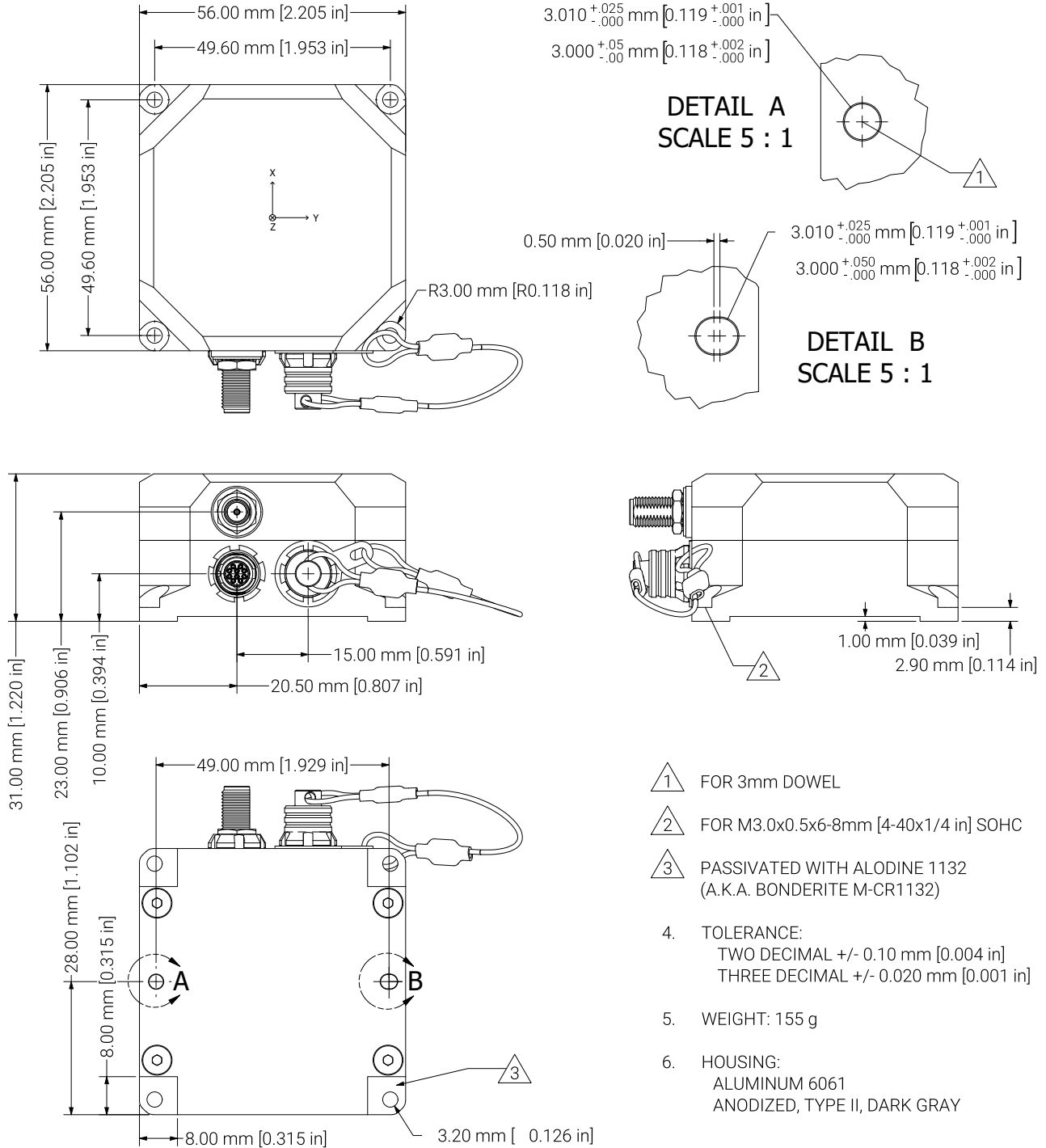

FIGURE 3

4.2 Environmental

Environmental

SPECIFICATION	MIN	TYP	MAX	UNITS	NOTES
Operating Temperature	-40		85	°C	
Storage Temperature	-40		85	°C	
MTBF	21000			Hr	[1]

[1] The environment assumption was an Airborne Uninhabited Cargo (AUC) with 100 % duty cycle, which includes environmentally uncontrolled areas which cannot be inhabited by an aircrew during flight. Contact VectorNav for more information.

TABLE 9

5 ELECTRICAL

Pinout Schematic

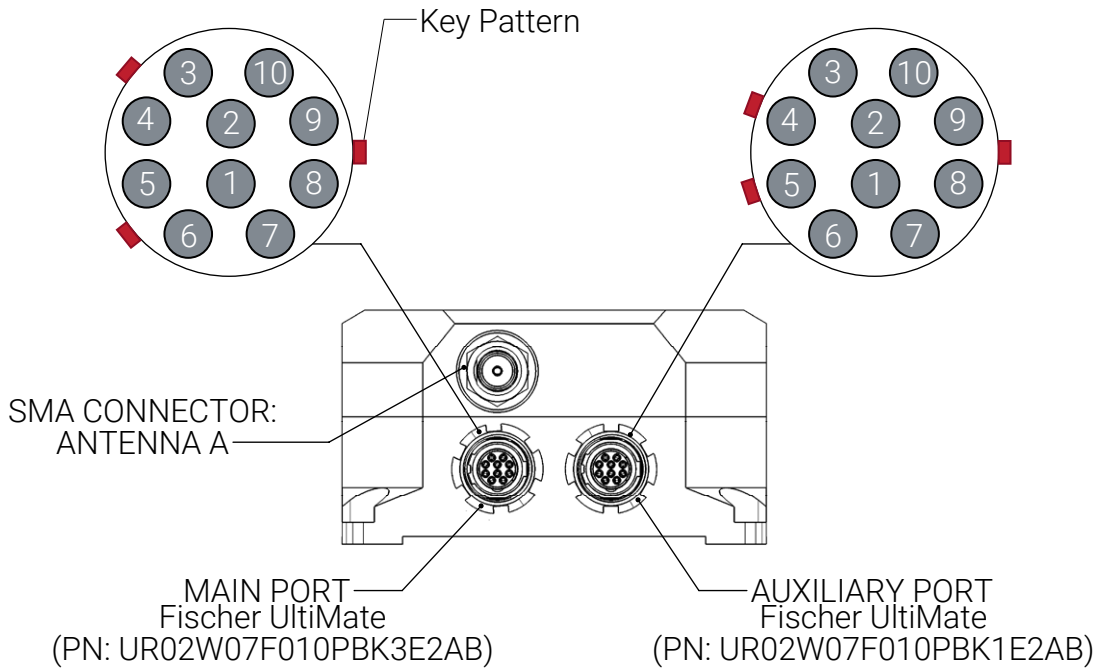

FIGURE 4

Main Port Pin Assignments

PIN	PIN NAME	TYPE	DESCRIPTION
1	SYNC_IN	Input	Input signal for synchronization purposes. Software configurable to either synchronize the measurements or the output with an external device
2	GPS_PPS	Output	GPS time pulse. One pulse per second, synchronized on rising edge. Pulse width is 100 ms.
3	SYNC_OUT	Output	Output signal used for synchronization purposes. Software configurable to pulse when ADC, IMU, or attitude measurements are available.
4	RX1	Input	RS-232 voltage levels data input to sensor
5	RESV	N/A	Reserved for internal use. Do not connect
6	RESV	N/A	Reserved for internal use. Do not connect
7	TX1	Output	RS-232 voltage levels data output from sensor
8	SIG_GND	Input	Ground reference for digital input/output signals.
9	VIN+	Supply	12 V to 34 V power input.
10	VIN-	Supply	Power ground (0 V).

TABLE 10

Aux Port Pin Assignments

PIN	PIN NAME	TYPE	DESCRIPTION
1	SYNC_IN_2	Input	Input signal for interfacing with an external IMU or GNSS receiver.
2	RESV	N/A	Reserved for internal use. Do not connect
3	RESV	N/A	Reserved for internal use. Do not connect
4	RX2+	Input	Serial RS-422 non-inverted input.
5	RX2-	Input	Serial RS-422 inverted input.
6	TX2-	Output	Serial RS-422 inverted output.
7	TX2+	Output	Serial RS-422 non-inverted output.
8	SIG_GND_2	Input	Ground reference for digital input/output signals.
9	VOUT+	Supply	12 V to 34 V power output.
10	VOUT-	Supply	Power ground (0 V). Tied directly to VIN-.

TABLE 11

5.1 Power

Input Power Supply

SPECIFICATION	MIN	TYP	MAX	UNITS	NOTES
Input Voltage (VIN)	12		34	V	
Power Consumption			2.7	W	[1]
Current (VIN @ 24 V)		110		mA	[1]

[1] Not including active antenna power consumption

TABLE 12

Output Power Supply

SPECIFICATION	MIN	TYP	MAX	UNITS	NOTES
Output Voltage (VOUT)		VIN		V	
Output Current			0.5	A	Temp=25 °C

TABLE 13

VIN

The power supply on the VN-210-A was designed to meet the requirements of MIL-STD-1275E which defines the operating voltage limits and transient voltage characteristics for electronic circuits in military ground vehicle platforms. For additional details about the MIL-STD certifications for the VN-210-A, refer to the Environmental section.

VOUT

The VOUT pins benefit from all the protective circuitry of the VIN pins; however, additional current protective circuitry is provided to protect the VN-210-A from shorts. The VOUT pins act as a pass-through, so the VOUT pins will have the same power supply specifications as supplied to the VIN pins.

5.2 General Purpose I/O

SYNC_IN

The SYNC_IN pin is a 5V tolerant input that drives SyncIn Events. It can be configured to detect either rising or falling edges. A SyncIn Event occurs when an internal counter exceeds a user defined SyncInSkipFactor. This allows SyncIn Events to occur at some multiple of the input signal such that a high-frequency input signal can be provided that is divided to the desired rate (eg. providing a 10 kHz signal that the sensor responds to only every 100 triggers will yield a 100 Hz response). At every SyncIn Event timeSyncIn is reset and syncInCount is incremented. SyncIn Events can also be configured to trigger several other actions (see the VN-210-A Interface Control Document for more details).

SYNC_OUT

The SYNC_OUT pin is an output pin with configurable output polarity and pulse-width that is driven by SyncOut Events. A SyncOut Event occurs when an internal counter

exceeds the user configurable SyncOutSkipFactor. The internal counter is incremented at a configurable rate defined by the SyncOutMode (See VN-210-A Interface Control Document for more details).

GPS_PPS

The GPS_PPS pin is an output pin that is directly connected to the onboard GNSS receiver. It provides a very accurate timing reference that is aligned to the GPS signal. While the GPS has a valid time reference fix, the accuracy for the time pulse signal is better than 60 ns 99% of the time. The signal is a square wave, synchronized to the rising edge that pulses high for 100 ms.

SYNC_IN_2

The SYNC_IN_2 pin is a 5V tolerant input that is reserve for interfacing with external IMUs or external GNSS receivers. Leave as no connect if not in use. For more information about the external IMU and external GNSS capabilities of the VN-210-A, refer to the User Manual.

SYNC_IN Specifications

SPECIFICATION	MIN	TYP	MAX	UNITS	NOTES
Input Logic-Low Voltage			0.8	V	
Input Logic-High Voltage	2.3			V	
Pulse Width	20			ns	
Pull-up Resistor		10		kΩ	
ESD Protection		±2.5		kV	

TABLE 14

SYNC_OUT Specifications

SPECIFICATION	MIN	TYP	MAX	UNITS	NOTES
Output Logic-Low Voltage			0.8	V	
Output Logic-High Voltage	2.9			V	
Pulse Width	20			ns	
Rise Time			5	ns	
Fall Time		3	6	ns	
Output Frequency	1		1000	Hz	
Jitter			20	μs	
Sink/Source Current	-15		15	mA	
ESD Protection		±2.5		kV	

TABLE 15

GPS_PPS Specifications

SPECIFICATION	MIN	TYP	MAX	UNITS	NOTES
Output Logic-Low Voltage			0.8	V	
Output Logic-High Voltage	2.9			V	
Pulse Width	20			ns	
Propagation Delay		20	30	ns	
Time Accuracy		30	60	ns	
Sink/Source Current	-15		15	mA	
ESD Protection		±2.5		kV	

TABLE 16

SYNC_IN_2 Specifications

SPECIFICATION	MIN	TYP	MAX	UNITS	NOTES
Input Logic-Low Voltage			0.8	V	
Input Logic-High Voltage	2.3			V	
Pulse Width	20			ns	
Pull-up Resistor		10		kΩ	
ESD Protection		±2.5		kV	

TABLE 17

5.3 Communication

This sensor utilizes full galvanic isolated full-duplex transceivers on both the primary and secondary connections. This feature helps to guard against large ground-to-ground differentials and common-mode transients. The galvanic isolation also helps to protect against the formation of potentially dangerous ground loops between the navigation module and the host system. This

is very important for cases where the power is provided from a different system than the host system communicating with the device. The galvanic isolation provides complete electrical separation between the power and data/communication interfaces, enabling the device to operate in situations where there is a significant ground potential difference between various systems.

UART-1 RS232 Interface Specifications

SPECIFICATION	MIN	TYP	MAX	UNITS	NOTES
Input Logic-Low Voltage	-25		0.8	V	
Input Logic-High Voltage	2.5		25	V	
Output Logic-Low Voltage		-5.7	-5	V	
Output Logic-High Voltage	5	6.2		V	
Data Rate	9600		921600	bps	
ESD Protection		±10		kV	

TABLE 18

UART-2 RS422 Driver Interface Specifications

SPECIFICATION	MIN	TYP	MAX	UNITS	NOTES
Differential Driver Output Voltage	2.1		5	V	
Difference in Magnitude of Driver Differential Output Voltage for Complementary Output States			0.2	V	
Driver Common Mode Output Voltage			3	V	
Difference in Magnitude of Driver Common Mode Output Voltage for Complementary Output States			0.2	V	
Maximum Driver Short-Circuit Current	-250		250	mA	
Data Rate	9600		921600	bps	
ESD Protection		±10		kV	

TABLE 19

UART-2 RS422 Receiver Interface Specifications

SPECIFICATION	MIN	TYP	MAX	UNITS	NOTES
Receiver Input Resistance	96	125		kΩ	
Receiver Termination Resistance Enabled	108	120	156	Ω	[1]
Receiver Input Current (RX- to RX+)	-100		125	μA	
Receiver Differential Input Threshold Voltage (RX- to RX+)	-0.2		0.2	V	
Receiver Differential Input Voltage (RX- to RX+)	-6		6	V	
Receiver Common Mode Input Voltage	-7		12	V	
Data Rate	9600		921600	bps	
ESD Protection		±10		kV	

[1] The stock configuration does not provide a termination resistor between pins RX- and RX+. If this feature is required it can be supplied as a special build option. Please contact VectorNav for more information.

TABLE 20

6 PRODUCT HANDLING AND INSTALLATION

6.1 Alignment and Fastening

When designing the installation location of the sensor, alignment pins can be used to precisely align the sensor to the system. VectorNav recommends using 3 mm dowel pins from McMaster-Carr (PN:93600A267). When fastening the VN-210-A, VectorNav recommends torquing the screws to 2.5 N m and 2.0 N m for steel and aluminum bases, respectively.

6.2 Magnetic and Vibration Considerations

Magnetic disturbances and vibration are two forms of interference that can reduce performance and accuracy for an orientation sensor. In most applications it is not possible to avoid magnetic and vibration interference entirely, so the effect of these disturbances on the navigation sensor need to be minimized by careful design.

Magnetic Interference

Magnetic interference occurs when nearby objects emit either a static or time-varying magnetic field that interferes with the navigation sensor's ability to measure the background Earth's magnetic field which is used to estimate heading. Components such as electric motors, iron-core inductors, and current carrying wires can emit a magnetic field which will interfere with the VN-210-A.

Static magnetic fields do not vary with time. This type of static interference can be compensated for by performing a hard/soft iron calibration of the magnetometer on the VN-210-A if the component creating the interference rigidly rotates with the sensor and always maintains the same distance and direction with respect to the sensor. If the source of the magnetic field rotates separately from the sensor, for instance is installed on a separate moving platform or arm, then it cannot be compensated for using a hard/soft iron calibration. Where possible attempt to locate the sensor as far away from sources of magnetic interference as possible.

Dynamic magnetic fields vary with time and are created by items such as electric motors or current carrying wires. This form of magnetic distortion is very difficult for the sensor to handle without adverse effect on navigation performance. When designing the navigation sen-

sor into your product pay careful attention to the location of current carrying conductors and their location with respect to the sensor. Where possible move these wires as far away from the sensor as possible to reduce its effect on the sensor's performance.

Vibration

The VN-210-A has been incorporated into numerous helicopter, racing vehicles, and fixed winged aircraft applications. Whether your application is one of the aforementioned or another use case, there are a few important considerations with regard to vibration when using the VN-210-A.

VectorNav recommends rigidly mounting the sensor with no vibration isolation. Vibration isolation is difficult to implement correctly and can degrade the performance of the sensor if done incorrectly. However, if isolation is determined to be necessary, the best practice is to isolate the subsystem that the VN-210-A is on or isolate the source of vibration.

Note that random vibrations on the order of 4.5 g RMS will saturate the accelerometers, causing significant performance degradation of the navigation filters.

6.3 Maintenance

There is no recommendation for returning the unit for recalibration. The factory calibrations are effective over the life of the part.

6.4 Cabling

The VN-210-A uses a 10-Pin Fischer UltiMate connector for the primary and auxiliary ports, each with different keying to prevent inadvertent cable swaps. VectorNav manufactures various cables at various lengths for the primary and auxiliary ports, including cables terminated in: (a) a DB15, (b) USB, or (c) a pigtail cable. Contact VectorNav for the full suite of manufactured cables. When building cables, VectorNav uses the connectors *Fischer UltiMate UP01L07 M010S BK3 Z2ZB* for the primary port and *Fischer UltiMate UP01L07 M010S BK1 Z2ZB* for the auxiliary port. Customers building their own cable should contact Fischer Connectors directly for additional connector options.



VectorNav Technologies, LLC
10501 Markison Rd
Dallas, TX 75238, USA

Tel: +1.512.772.3615
Email: sales@vectornav.com
Web: vectornav.com

© 2023 VectorNav Technologies, LLC. All rights reserved.
VectorNav and the Diamond & Triangles logo are trademarks of VectorNav Technologies, LLC.
Version 25-210-A-30-R1-R1